

# Hy-Lok CNG Products

Receptacles, Ball & Check Valves  
Filters, Tube Fittings

Catalog No. H - CNG100  
Jan. 2007



**HY-LOK CORPORATION**

©2007 HY-LOK CORPORATION All rights reserved

### Introduction

Hy-Lok's receptacle is designed for permanent mounting to a compressed natural gas vehicle(NGV).

QC1 Series receptacle utilizes the AGA / CGA NGV 1 profile allowing complete interchangeability to any nozzle conforming to the AGA / CGA NGV 1 standard.

QC2 Series receptacle is designed specifically for bus and trucks refuelling. receptacle is designed to provide superior flow characteristics.

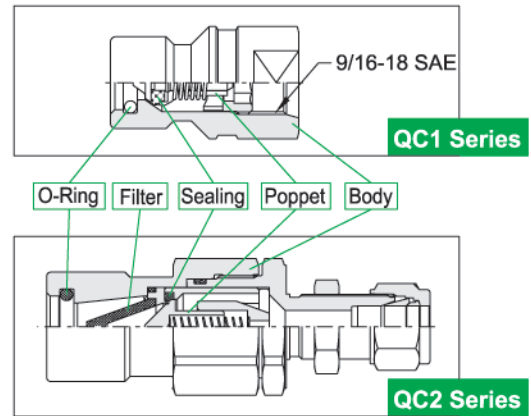

### Features

- Receptacle contains a highly reliable non-contact check valve that opens only when differential pressure is present during fueling.
- Internal check valve provides unidirectional flow.
- Construction material - available in stainless steel or brass.
- Self-Centering Poppet.
- Standard protective dust caps are supplied with all receptacles.
- Optionally with particle filter available (50 Micron).

### Technical Data

- Maximum Operating Pressure : **3600 psig @ 100 °F (38 °C)**
- Operating Temperature Range :  
**From -40 °F to 250 °F (-40 °C to 121 °C)**

### Material of Construction

Description	Material / ASTM Specification	
Body	SS316 / A479	BRASS / B16
Poppet	SS316 / A479	
Sealing	NBR	
O-Ring	NBR	

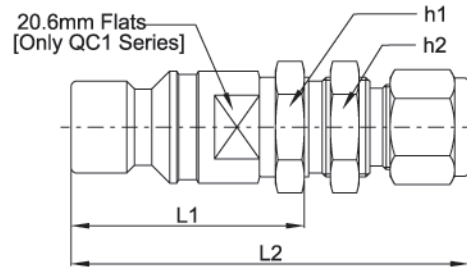

### Table of Dimensions

Basic Part No.	End Connection	Width across flat				Dimensions, in.(mm)	
		h1		h2		L1	L
		in.	mm	in.	mm		
QC1CB - 4	1/4 Hy-Lok	11/16	17.4	5/8	15.8	1.91"(48.5)	3.23"( 82.0)
QC1CB - 6	3/8 Hy-Lok	3/4	19.1	3/4	19.1	1.96"(49.8)	3.41"( 86.6)
QC1CB - 8	1/2 Hy-Lok	1	25.4	1	25.4	2.05"(52.0)	3.48"( 88.4)
QC1CB - 6M	6M Hy-Lok	-	18.0	5/8	15.8	1.91"(48.5)	3.23"( 82.1)
QC1CB - 10M	10M Hy-Lok	-	22.0	-	22.0	1.96"(49.8)	3.41"( 86.8)
QC1CB - 12M	12M Hy-Lok	-	24.0	15/16	23.8	2.05"(52.0)	3.49"( 88.6)
QC2CB - 12M	12M Hy-Lok	-	36.0	15/16	23.8	2.74"(69.5)	4.39"(111.4)
QC2CB - 16M	16M Hy-Lok	-	36.0	-	27.0	2.74"(69.5)	4.41"(112.1)

\* Dimensions shown with Hy-Lok nuts in finger-tight position, where applicable.

### Ordering Information

**QC1**

**Series Designator**

- QC1 : NGV1 Receptacle
- QC2 : For Buses and Trucks

**CB**

**End Connection Designator**

- CB : Hy-Lok Tube Fitting
- CBZ : O-Ring Face Seal

**4**

**Size Designator**

- Tube O.D. Designation

Tube O.D.	1/4"	3/8"	1/2"	6mm	10mm	12mm	16mm
Designation	4	6	8	6M	10M	12M	16M

**S316**

**Body Material Designator**

- S316 : 316 Stainless Steel
- BRAS : Brass

### Introduction

Hy-Lok's CNG Series Manual Ball Valves are designed to live loaded type for long cycle life and high pressure. The valves provide quick 1/4 turn on-off control of flow the vehicle tank to the engine. Tested and certified for this application per AGA / CGA NGV 3.1.

### Features

- Disc spring loaded seat
- Low operating pressure
- Handle indicates direction of flow
- Panel mounting
- 1/4 turn on-off control
- 316 Stainless Steel construction
- Bi-directional flow
- 100% factory tested

### Technical Data

- Maximum Operating Pressure : **6000 psig @ 100 °F (38 °C)**
- Operating Temperature Range :  
**From -40 °F to 250 °F (-40 °C to 121 °C)**
- Cv Ratings : **1.04 to 2.3**

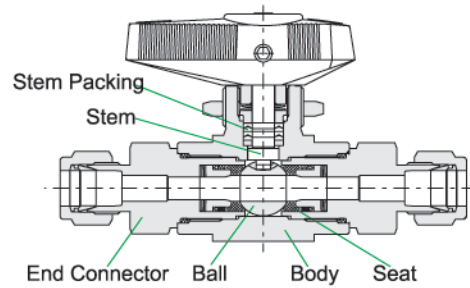

### Material of Construction

Description	Material / ASTM Specification
Body	SS316 / A182 or A479
End Connection	SS316 / A479
Ball	SS316 / A479
Stem	SS316 / A479
Stem Packing	PCTFE
Seats	PEEK
Seals	Viton

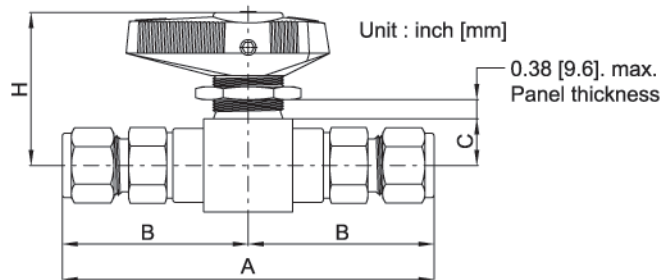

### Table of Dimensions

Basic Part No.		Orifice in. (mm)	Cv	End Connection		Dimensions, in. (mm)			
				Inlet	Outlet	A	B	C	H
CNG1B	H -4T	0.188(4.8)	1.04	1/4" Hy-Lok	1/4" Hy-Lok	4.14 (105.2)	2.07 (52.6)	0.57 (14.5)	1.89 (48.4)
	H -6T	0.244(6.2)	2.30	3/8" Hy-Lok	3/8" Hy-Lok	4.39 (111.2)	2.19 (55.6)		
	H -8T			1/2" Hy-Lok	1/2" Hy-Lok	4.60 (116.8)	2.30 (58.4)		
CNG2B	H -8T	0.410(10.3)	6.42	1/2" Hy-Lok	1/2" Hy-Lok	4.68 (118.8)	2.34 (59.4)	0.71 (18.0)	2.28 (57.8)
	H -12T			3/4" Hy-Lok	3/4" Hy-Lok				
CNG1B	H -6M	0.188(4.8)	1.04	6mm Hy-Lok	6mm Hy-Lok	4.14 (105.2)	2.07 (52.6)	0.57 (14.5)	1.89 (48.4)
	H -10M	0.244(6.2)	2.30	10mm Hy-Lok	10mm Hy-Lok	4.40 (111.8)	2.20 (55.9)		
	H -12M			12mm Hy-Lok	12mm Hy-Lok	4.60(116.8)	2.30 (58.4)		
CNG2B	H -12M	0.374(9.5)	5.57	12mm Hy-Lok	12mm Hy-Lok	4.68 (118.8)	2.34 (59.4)	0.71 (18.0)	2.28 (57.8)
	H -16M	0.410(10.3)	6.42	16mm Hy-Lok	16mm Hy-Lok				

\* Dimensions shown with Hy-Lok nuts in finger-tight position, where applicable.

### Ordering Information

**CNG1B**

#### Series Designator

- CNG1B : Orifice 6.2mm
- CNG2B : Orifice 10.3mm

**H**

#### End Connection Designator

- H : Hy-Lok Tube Fitting
- F : Female Thread

**4T**

#### Size Designator

- Pipe Thread NPT (ISO/BSP)

Pipe Size	1/8"	1/4"
Designator	2N	4N

- Tube O.D. Designation

Tube O.D.	1/4"	3/8"	1/2"	6mm	8mm	10mm	12mm
Designator	4T	6T	8T	6M	8M	10M	12M

**S316**

#### Body Material Designator

- S316 : 316 Stainless Steel

## Introduction

Hy-Lok's 700H Series Check Valves are designed for flow control CNG. Tested and certified for this application per AGA/CGA NGV 3.1.

## Features

- Inline check valve.
- Back stopped pppet.
- NBR seat design.
- Cracking pressure inclue : 1/3, 1, 5, 10, 25psig.
- Indicator Ring for easy identify the cracking pressure.
- 100% factory tested.

## Technical Data

- Maximum Operating Pressure : **6000 psig @ 100 °F (38 °C)**
- Operating Temperature Range :  
**From -40 °F to 250 °F (-40 °C to 121 °C)**
- Flow Coefficient(Cv) : **0.67 to 4.7**

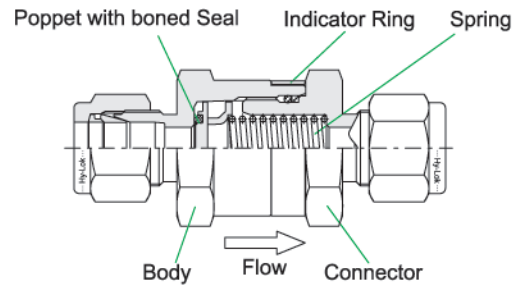

## Material of Construction

Description	Material / ASTM Specification
Body	SS316 / A479
Connector	SS316 / A479
Sealing	NBR
Spring	SS302
Indicator Ring	Stainless Steel

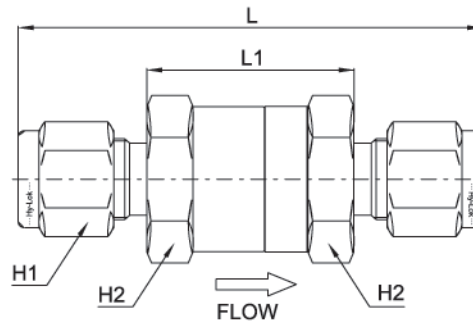

## Table of Dimensions

Basic Part No.	End Connection	Hexagon, in.(mm)				Dimensions, in.(mm)	
		h1		h2		L1	L
		in.	mm	in.	mm		
CVH1-H4T	1/4 Hy-Lok	9/16	14.20	11/16	17.46	1.04"(26.4)	2.43"(61.7)
CVH1-ZCO4	1/4" O-Ring Face Seal	-	-				1.98"(50.3)
CVH2-H8T	1/2" Hy-Lok	3/4	22.22	1	25.4	1.23"(31.2)	2.96"(75.2)
CVH2-H8M	1/2" Hy-Lok	3/4	16.00				2.70"(68.6)
CVH2-H10M	10mm Hy-Lok	-	19.00				2.80"(71.1)
CVH2-H12M	12mm Hy-Lok	-	22.00				2.96"(75.2)
CVH2-H16M	16mm Hy-Lok	-	25.00				1.42"(36.0)
CVH2-ZCO8	1/2" O-Ring Face Seal	-	-	1.23"(31.2)	2.35"(59.7)		
CVH3-H12T	3/4" Hy-Lok	1 1/8"	28.58	1 5/8"	41.28	1.78"(45.2)	3.52"(89.4)
CVH3-ZCO12	3/4" O-Ring Face Seal						2.90"(73.7)

\* Dimensions shown with Hy-Lok nuts in finger-tight position, where applicable.

## Ordering Information

**CVH1**

### Series Designator

- CVH1 : Orifice 4.8mm
- CVH2 : Orifice 7.8mm
- CVH3 : Orifice 15.2mm

**H**

### End Connection Designator

- H : Hy-Lok Tube Fitting
- F : Female Thread
- M : Male Thread
- V : Metal Gasket Face Seal
- ZCO : O-Ring Face Seal

**4T**

### Size Designator

**1/3**

### Cracking Pressure Designator

- 1/3 : 1/3 psig
- 1 : 1 psig
- 5 : 5 psig
- 10 : 10 psig
- 25 : 25 psig

**S316**

### Body Material Designator

- S316 : 316 Stainless Steel

• Pipe Thread NTP(ISO/BSP)

Pipe Size	1/8"	1/4"
Designator	2N(R)	4N(R)

• Tube O.D. Designation

Tube O.D.	1/4"	3/8"	1/2"	3/4"	8mm	10mm	12mm	16mm
Designator	4T	6T	8T	12T	8M	10M	12M	16M

### Introduction

Natural Gas Vehicle Filter product is designed to protect critical engine components in compressed natural gas Vehicles(NGV). Contaminants can be introduced into the vehicle's fuel tank when being fueled. Contaminants may come from CNG compressors and storage facilities. These unit is specifically designed to remove oil, water and solid contamination from compressed natural gas. The Hy-Lok's filter remove over 95% of all aerosols in the 0.3 to 0.6 micron range.

### Features

- Hy-Lok's filter is designed to use with CNG systems.
- Durable construction and simple servicing.
- Small size allows for installation versatility.
- Removes over 95% of all aerosols in the 0.3 to 0.6 micron range.
- Easy to change filter element.
- Maximum burst pressure of 16000psig.

### Technical Data

- Maximum Operating Pressure : **3600 psig @ 100 °F (38 °C)**
- Operating Temperature Range :  
**From -40 °F to 250 °F (-40 °C to 121 °C)**
- Rated Flow : **30 SCFM @ 100psig**
- Pressure Drop : **0.5 to 1psig**

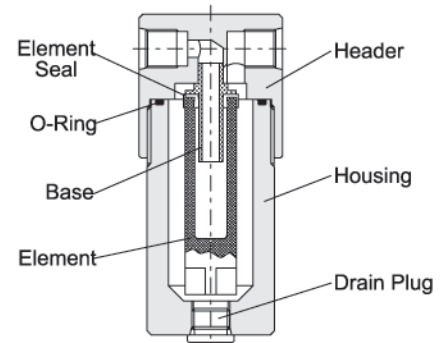

### Material of Construction

Description	Material / ASTM Specification
Header	Anodized Aluminum 6061
Housing	Anodized Aluminum 6061
Seal (O-Ring)	NBR
Filter Element	Polyethylene (Gade 10)
Drain Plug	Stainless Steel 316
Base	Nylon

### Installation Diagram

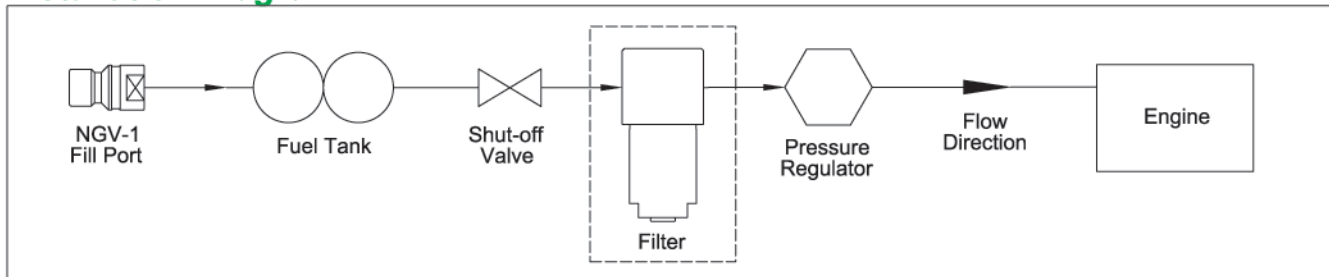

### Dimensions and Note

#### Installation Note

The unit should be located in an accessible and protected location for easy servicing. Maintain at least 3" (76mm) of clearance below the unit for element access. The drain port must face down.

#### Service Note

The unit must not be under pressure during serving. Injury to personnel may result. Close the shut-off valve shown in the illustration above and slowly relieve line pressure before attempting service.

#### Replacing the Element

Change the element at the same time as engine oil filter changes or at least every 5000km.

#### Draining the Housing

Drain the housing every 2500km or as necessary. With line pressure relieved, remove the drain plug using a wrench, then cleaning the plug.

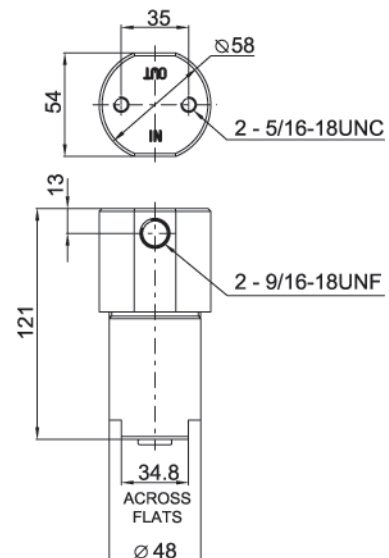



### MICRON TEE FILTER

#### Features

- Replacement of filter elements with body in line.
- Compact and robust integral union bonnet design.
- Filter elements are made of sintered stainless steel.

#### Technical Data

Maximum Operating Pressure : 6000 psig @ 100 °F (38 °C)

Operating Temperature Range :

From -40 °F to 250 °F (-40 °C to 121 °C)

#### Material of Construction

Description	Material / ASTM Specification
Body	SS316 / A479
Sintered Element	Stainless Steel
Seal (O-Ring)	Viton
Element Seal	PTFE

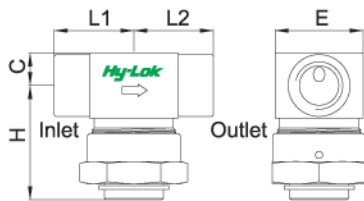

#### Table of Dimensions

Basic Part No.	Orifice (mm)	End Connection Inlet & Outlet	Dimensions (mm)				
			L1	L2	H	C	E
FT	H -4T	1/4" Hy-Lok	33.0	33.0	38.8	11.0	28.5
	H -6T	3/8" Hy-Lok	36.2	36.2			
	H -8T	1/2" Hy-Lok	38.7	38.7			
	H -8M	8mm Hy-Lok	38.7	38.7			
	H -12M	12mm Hy-Lok	38.7	38.7			
	H -16M	16mm Hy-Lok	38.7	38.7			

\* Dimensions shown with Hy-Lok nuts in finger-tight position, where applicable.

#### Ordering Information

<b>FT</b> Filter Type Designator	<b>H</b> End Connection Designator H : Hy-Lok Tube Fitting F : Female Thread M : Male Thread	<b>4T</b> Size Designator Tube O.D. Designation	<b>50</b> Filter Element Designator 1 : 1 Micron 10 : 10 Micron 50 : 50 Micron 100 : 100 Micron 150 : 150 Micron	<b>S316</b> Body Material Designator S316 : 316 Stainless Steel
-------------------------------------	--	---	--	---

### TUBE FITTING

#### Introduction

Hy-Lok's Tube Fittings are designed for excellent gas-tight sealing and vibration fatigue resistance.

Tested and certified for this application per ECE R110(for NGV application).

See our Tube Fitting Cataloge(H-200TF) for more information(working pressure, ordering information, Dimensions, Size, etc).

#### Tube Fitting Type

 Union <b>CUA</b>	 Reducing Union <b>CUR</b>	 Union Elbow <b>CLA</b>	 Union Tee <b>CTA</b>	 Union Cross <b>CXA</b>
 Bulkhead Union <b>CBU</b>	 Male Connector <b>CMC</b>	 Male Connector for Metal Gasket Seal <b>COM</b>	 Bulkhead Male Connector <b>CBMC</b>	 45 Male Elbow <b>CLMB</b>
 Male Elbow <b>CLMA</b>	 Female Connector <b>CFC</b>	 Bulkhead Female Connector <b>CBFC</b>	 Female Elbow <b>CLF</b>	 Reducer <b>CR</b>
 Bulkhead Reducer <b>CBR</b>	 SAE/MS Male Connector <b>CSC</b>	 SAE/MS Male Elbow <b>CSLA</b>	 O-Seal Straight Thread Connector <b>COS</b>	 Male Pipe Weld Connector <b>CWC</b>